

CAD FILE:

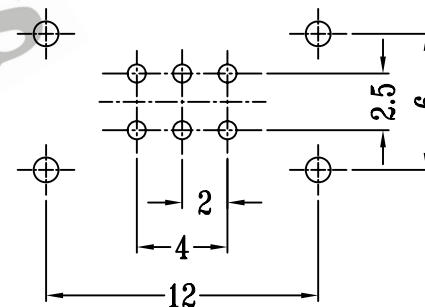

P.C.B LAYOUT

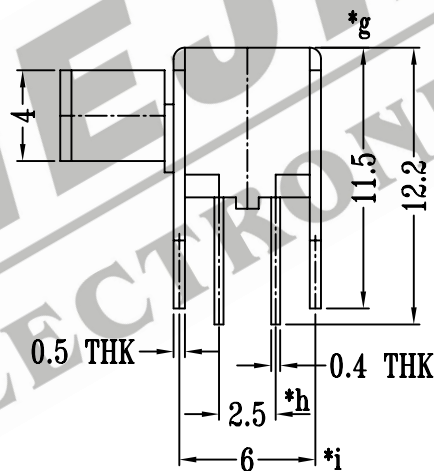
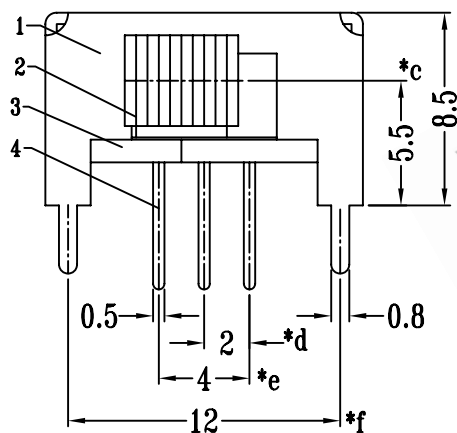
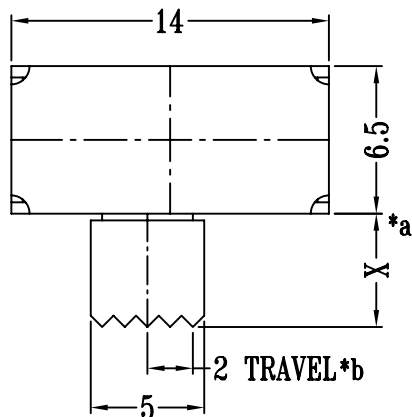
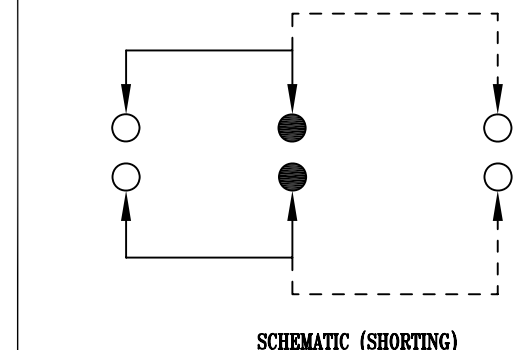

SCHEMATIC (SHORTING)

注:带*表示关键尺寸(7个)

NO.	PARTS	MATERIALS	Q'TY	FINISH	TOLERANCE UNLESS SPECIFIED	SHENZHEN XIEJIA ELECTRONICS CO.,LTD.					
8						ISSUE		DATE		DESCRIPTIONS OF REVISION	APPD.
7	CONTACT CLIP	PBS	2	Ag CLAD	WITHIN: 1.5±0.1mm	TITLE : HORIZONTAL SLIDE SWITCH		UNIT : mm	DRWG NO.: XJ-DR-SK22D14-00		
6	SPRING	STEEL WIRE	1	TEMPER	OVER: 1.5±0.2mm	MODEL: SK-22D14		SCALE: 3:1	DWN.	ZHOUYU	2004-7-31
5	STEEL BALL	STEEL	1	NATURAL		ALL MATERIALS MUST BE COMPLIANT TO ROHS			CHK'D	FANGYING	2004-7-31
4	TERMINAL	BRASS STRIP	6	Ag PLATED OVER Ni PLATED					APPD.	KANGXINAN	2004-7-31
3	BASE	PHENOLIC RESIN	1	NATURAL							
2	KNOB	POM	1	BLACK							
1	FRAME	STEEL STRIP	1	Ni PLATED							